

ECLIPSE AIR HEAT BURNERS

Dimensions—Series “CAH”

Data 140-4

11/93

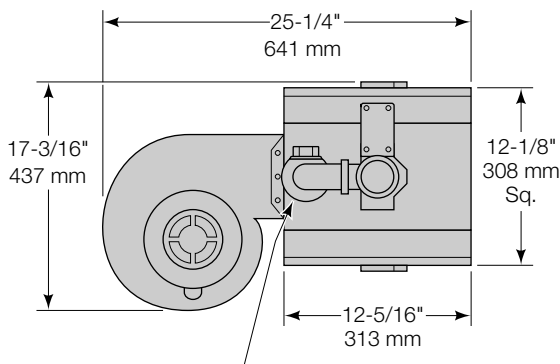

3/4" Check Valve
#550092

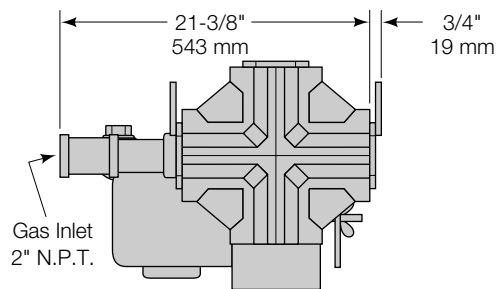

U.S. Reissue Pat. No. 26,244
Canadian Pat. No. 743,782

Burner Cat. No.	Assy. No.	Total Input				Blower Cat. No.†	Cross Section Area	
		MM Btu/Hr.		kW			Sq. In.	Sq. Cm.
		0.8MM Btu/Hr.	1.0MM Btu/Hr.	769 kW/M	962 kW/M			
160 CAH	111500	1.6	2.0	469	586	65-84S-1/3	230	1484

† See Data 140-5 for blower details.

Pilot Components & Dimensions

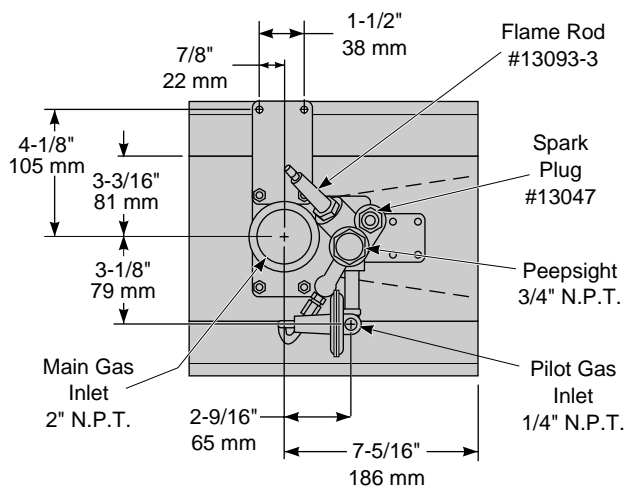
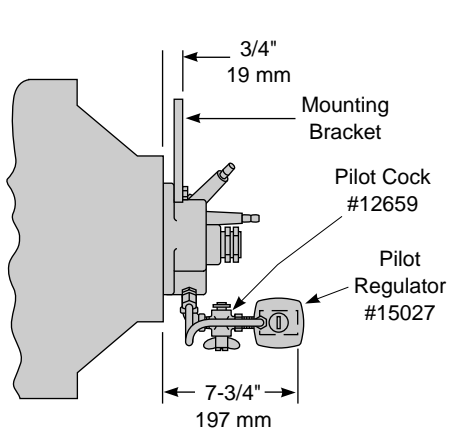

ECLIPSE COMBUSTION, INC.